



PACKAGING

High reliability, high speed: complete solutions for high performance

ARBURG

THE PACKAGING SPECIALIST

**“Packaging” ALLROUNDER: maximum
productivity with low energy requirements.**

Every one-hundredth of a second and every kilowatt-hour translate directly into cash – whether it's a one-gram closure or large-volume container. Which is why we have consistently designed our ALLROUNDERS for energy efficiency and maximum performance. Special versions of hybrid machines ensure maximum productivity – throughout the entire series production.

WIR SIND DA.



Top performance: the "Packaging" (P) version provides the basis for maximum production efficiency.

AT A GLANCE

// Milk stays fresh, mineral water retains its taste and paint keeps in its container. These are just a few applications for which our ALLROUNDER machines are used and that make life easier for you and your customers every day. No problems. Reliable. And, most importantly, in large unit volumes. We use the special "Packaging" (P) version and the CUBE, which is designed for cube-mould technology, to provide you with fast cycles and high reliability. Around the clock, 365 days a year. //

Important features of the "Packaging" (P) version

- Adapted design
- Extremely short dry cycle times
- High plasticising capacity and injection moulding speed
- Up to 30 percent reduced energy requirement

Utilising innovative technology

Packaging items require application-specific system solutions. This is precisely where the special “Packaging” (P) version of our hybrid ALLROUNDERS comes into play. Our modular design means that the best possible system design can be achieved for every application. Operate economically: with high-end injection moulding technology such as liquid-cooled drives, automatic clamping force regulation, and planetary roller screw drives.

Targeted process optimisation

Our intuitive machine control system enables you to manage complex processes simply, safely and quickly. The real-time plausibility check of all entries during programming represents a major advantage. Even special production processes can be created freely, without requiring special programs. Aiming for short cycle times? Controlled start to production required? Need effective process control? Our assistance packages help ensure you always get the best out of all processes.

Comprehensive service benefits

As a technology and system partner, ARBURG offers seamless support in the packaging sector from the idea to the production-ready product - world-wide. An interdisciplinary team is on hand to provide expert advice. They can answer questions ranging from machine and process engineering to tool design and from mould tests and machine comparisons to the evaluation of various technological alternatives: the focus here is always on finding the most rational solution for you.

“PACKAGING” (P) VERSION

<input checked="" type="checkbox"/> FEM-optimised mounting platens	<input checked="" type="checkbox"/> Highly wear-resistant cylinder modules with barrier screws
<input checked="" type="checkbox"/> Servo-electric toggle-type clamping units and dosing drives	<input type="checkbox"/> High-performance drives for even higher screw circumferential speeds
<input type="checkbox"/> Synchronisable servo-electric ejectors with booster function	<input checked="" type="checkbox"/> Highly dynamic, position-controlled injection with aXw Control ScrewPilot
<input type="checkbox"/> Individual media connections in the vicinity of the mould	<input type="checkbox"/> Individual bolt-type and needle shut-off nozzles
<input type="checkbox"/> Preparation for high-speed removal or IML system	<input checked="" type="checkbox"/> Control functions such as start-up parameters and dosage across cycles

Standard Option

MACHINE CONCEPT: PRODUCTIVITY

// Maximum productivity with high energy efficiency! We have innovative high-end technology for this complex task that works reliably, quickly and with high quality. Functionality, convenience, material savings and the best technical properties are increasingly required in packaging. In order to meet the trend for increasingly sophisticated products, you need flexible, individual injection moulding technology. In other words: ALLROUNDERS from ARBURG. //

Underlying modular system

Closures with integral dosage aids? Tamper-proof caps for beverages? Labelled tubs with integrated barrier coating for foodstuffs? The item to be manufactured dictates the system equipment. Our modular system always allows you to create individual configurations in terms of size, drive technology and equipment.



Servo-electric toggle systems enable up to
30 %
ENERGY SAVING

High-performance drive technology: simultaneous movements mean that short cycle times can be implemented without limits.

Generous installation space
and opening stroke: also
suitable for large moulds.

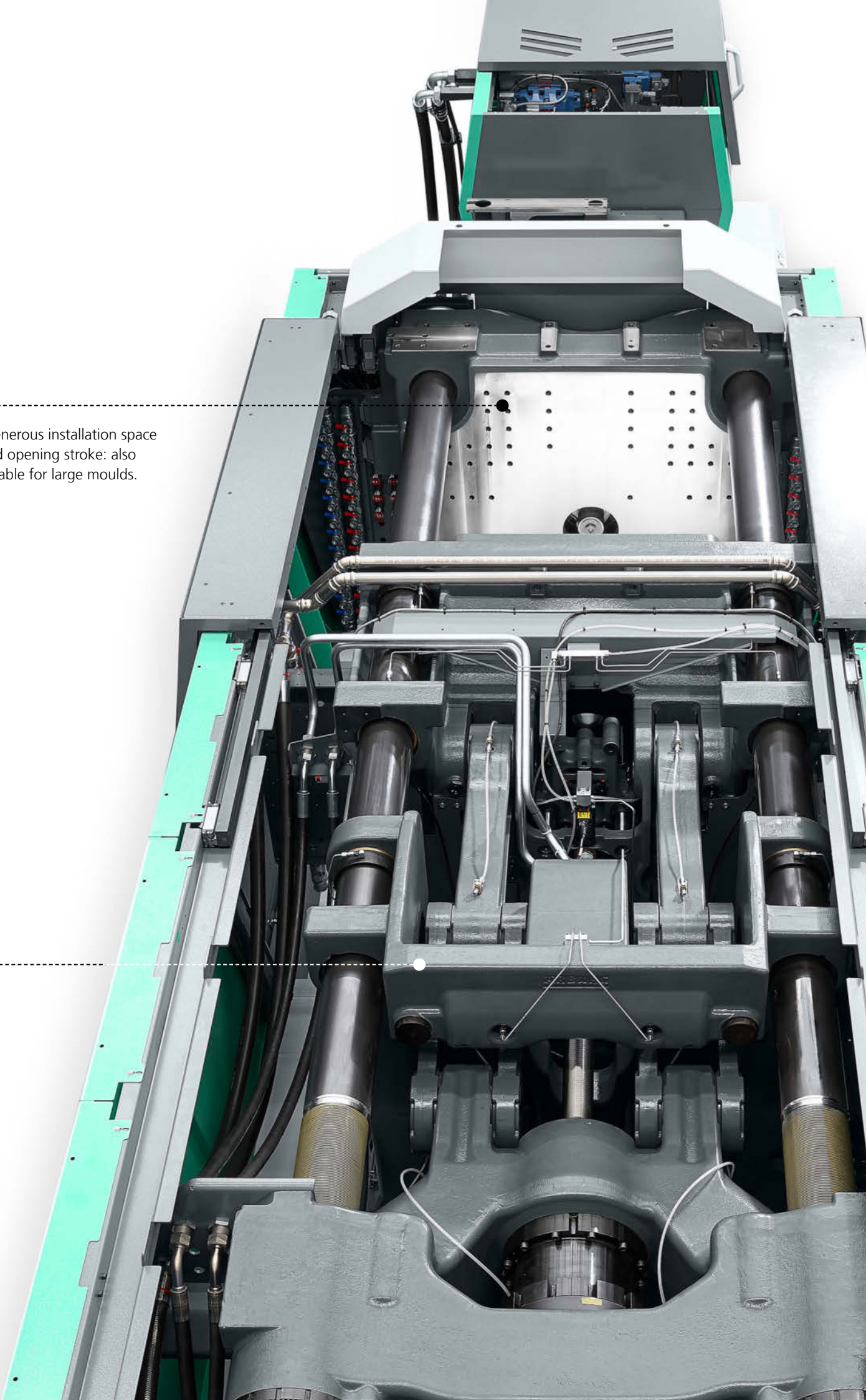

Reliable and powerful: the high-quality technology of the hybrid ALLROUNDERS.



Adapted design

The reliability of injection moulding machines over their entire service life depends not least on their design. The special "Packaging" (P) version ensures:

- Minimal mould breathing, thanks to FEM-optimised mounting platens
- Low mould wear, thanks to precisely guided clamping units
- Permanent process reliability through liquid-cooled drives

Electric toggle system

Servo-electric clamping units save a great deal of time and energy in comparison with hydraulic clamping units, also making them more cost-efficient. The cycle can be reduced thanks to extremely fast mould movements. Features such as energy recovery during braking effectively reduce energy requirements. Greater precision in the positioning of the servo electric clamping unit also leads to more reliable removal.

High plasticising capacity

So-called barrier screws, in which the compression zone has been replaced with a barrier zone, ensure homogeneous plasticising. In addition there is a servo-electric dosage drive. Since the melt can be dosed simultaneously and cyclically, it can also be processed more gently, even in fast cycles. High screw circumferential speeds permit minimal dosage times.



"PACKAGING" (P) ALLROUNDER

Distance between tie bars: **520 - 1020 mm**

Clamping forces: **1300 - 6000 kN**

Injection units: **290 - 7000**

7,300,000 CYCLES



per year - the "Packaging" (P) version transforms performance into top performance

TECHNICAL DETAILS: VERSATILE

// As a technology and system partner, ARBURG always looks at the whole picture. Injection moulding machine, mould and automation combine precisely, so that technical components become a fully functioning production plant. Whether in-mould-labelling or multi-component technology, machine configuration or turnkey solutions: our wide range of application-specific technical details can be relied upon always to provide you with the right production solution. //

Highly dynamic: servo valves arranged close to the consumer.

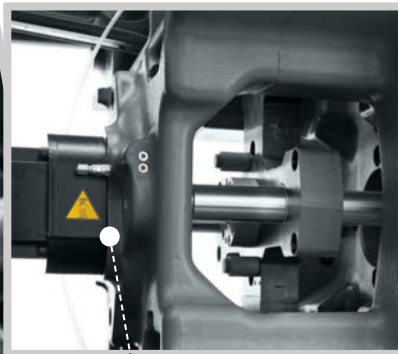
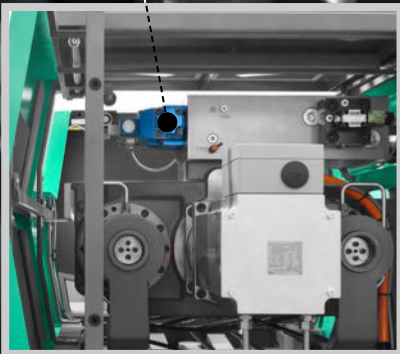

Precise and powerful: servo-electric ejector with hydraulic boost function.

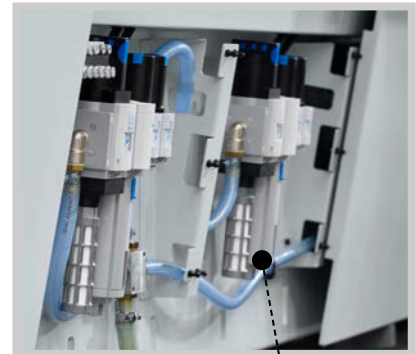

Fast actuation: valve clusters with large cross sections for pneumatic functions.

Fast, dynamic injection

Highly dynamic filling during injection moulding is important for thin-walled parts. This is the only way to reproducibly achieve the shortest possible injection times. Our unsurpassed ScrewPilot provides the basis for this. Correspondingly fast movements are achieved by means of hydraulic servo valves close to point of application and servo-electrically powered planetary roller screw drives.

Synchronous, powerful ejection

Precise, reproducible drop of the moulded parts for short opening and closing times – made possible by combining a servo-electric toggle-type clamping unit with a servo-electric ejector. With the hydraulic boost function, even shrink-fit closures can be demoulded with ease.

Tailored expansions

Large valve clusters help with the fast actuation of pneumatic functions in the mould. Mould cooling can be optimised through customer-specific cooling water distributors with feed lines with diameter of up to two inches. A dry air device above the clamping unit reliably prevents the formation of condensation.

System solutions

As a technology and system partner, ARBURG also assumes the overall responsibility for turnkey systems - from individual project planning and acquisition, commissioning and CE marking through to all the necessary services. This is made possible through close cooperation with leading manufacturers of moulds, automation systems and peripheral devices.

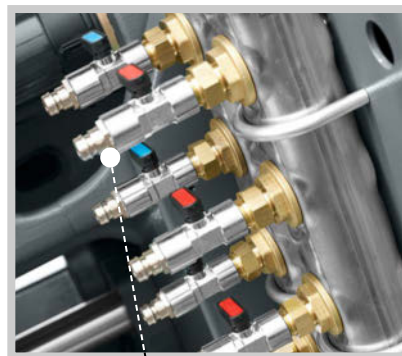

Highly customised: media connections in the vicinity of the mould.



Effective cooling: supply lines with large cross-sections.



There is no such thing as no can do: with a wide range of functions for specialised technology, you can make even special sequences standard.

CONTROL SYSTEM: SMART

// Maintaining control over the machine, mould, robotic technology and peripheral technology requires a suitably powerful central control system. This calls for smart technology that offers extensive data integration options, monitors and adaptively controls your process, and supports you in every operating situation.

All the features of our SELOGICA and GESTICA control systems are designed for a fast, secure and convenient set-up and operating process. This allows you to get the best out of all your applications. //

Highlights

- SELOGICA and GESTICA – fully compatible
- Graphic sequence programming
- Direct plausibility checks
- Assistance packages and connectivity modules
“Ready for Digitalisation”
- Central control system for complete production cells

i // Further information:
SELOGICA and GESTICA brochure

Flexible sequence management

The required production sequence can be adapted to suit the specific application, with no need for special programs. Freely configurable ramps ensure that movements remain harmonious and reliable even at high speeds. Equally unique: the monitoring of any machine, mould and peripheral signals for process- or quality control. Follow-up functions can be individually selected. Example: production will only start if compressed air is available. This kind of set-up freedom is unique to our machine control system.

Reliable production start-up

A controlled production start ensures maximum process reliability and efficiency. One-time setting of start-up parameters and cycles eliminates the need for manual adjustments. All values are saved in the data set.

Process optimisation

Whether you need synchronised movements, depending on the paths or forces, simultaneous injection as the mould closes (injection on the fly), or robotic system advancement as the mould opens, our machine control system offers you almost limitless possibilities for process optimisation.

Fully integrated: dedicated symbols for special mould functions.

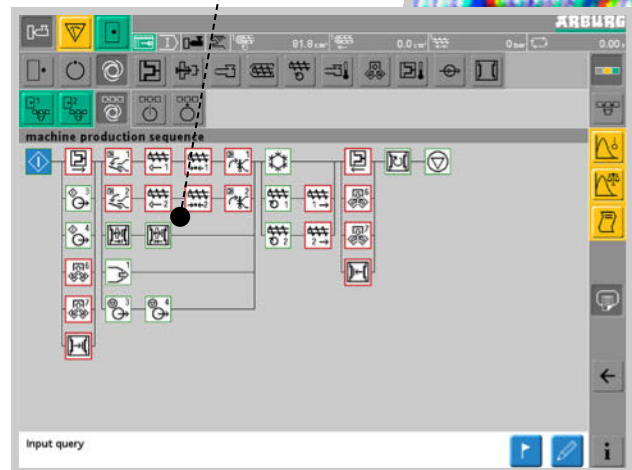
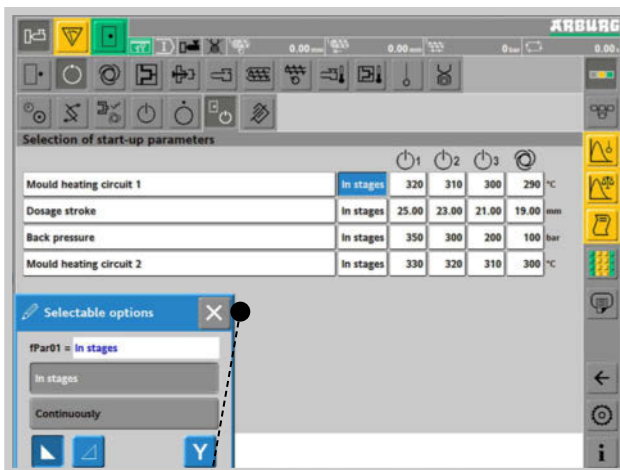

Safe: start-up is set once and is then always started automatically at the start of production.

APPLICATIONS: IN PRACTICE

// Speed, a high degree of reliability and quality are essential to ensure optimum performance on a daily basis. These are precisely the features that characterise our ALLROUNDER "Packaging" (P) machine. As a technology and system partner, we take care of high-performance complete solutions with machines that are precisely tailored to your application. Professional support from planning to installation and service round off our offer. This means that you are quickly on the safe side when it comes to packaging. //

Turnkey: complete production cells for packaging technology from a single source.

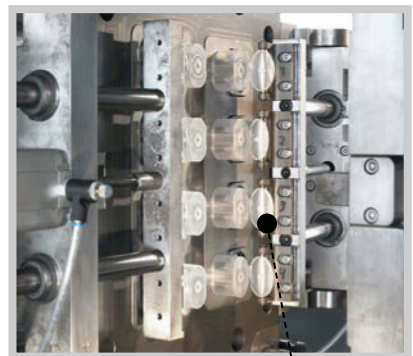

High-quality: flip-top closures attached directly in the mould.



Want to watch our videos to find out more?

Scan this code to visit our Media Centre.
unserer Mediathek.

Versatile and secure: closures for a variety of requirements.



Productive: 72 screw caps in 3 seconds
through synchronized ejection.

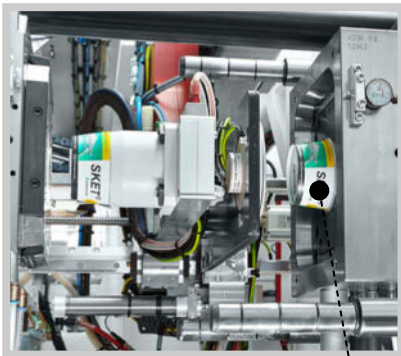

Time-saving: simultaneous
insertion of labels and
removal of containers.

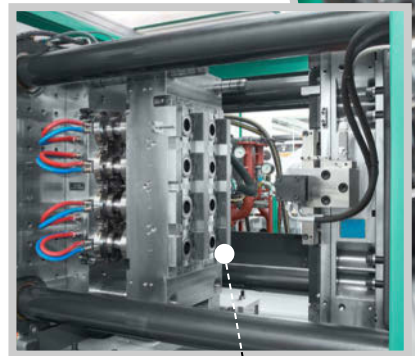
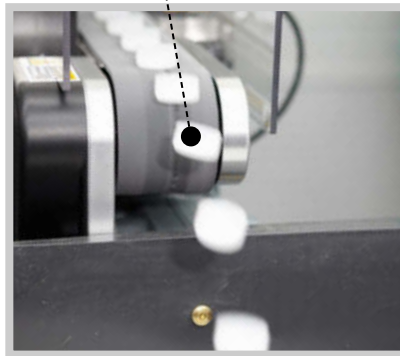

Dynamic: achieve long flow paths with
short injection times - for example
when producing cartridges.

i / Further information:
Turnkey projects brochure



Scan this code to visit our
Media Centre: in-depth,
captivating, entertaining.

ARBURG GmbH + Co KG
Arthur-Hehl-Strasse
72290 Lossburg
Tel.: +49 7446 33-0
www.arburg.com
contact@arburg.com

WIR SIND DA.